

Cangzhou Changyuan Fittings Co.,Ltd

Add:No.26 Shigang Road,Development Zone,Cangzhou ,Hebei,China Pc:061000

[Http://www.con-well.com](http://www.con-well.com) email:con-well@vip.163.com

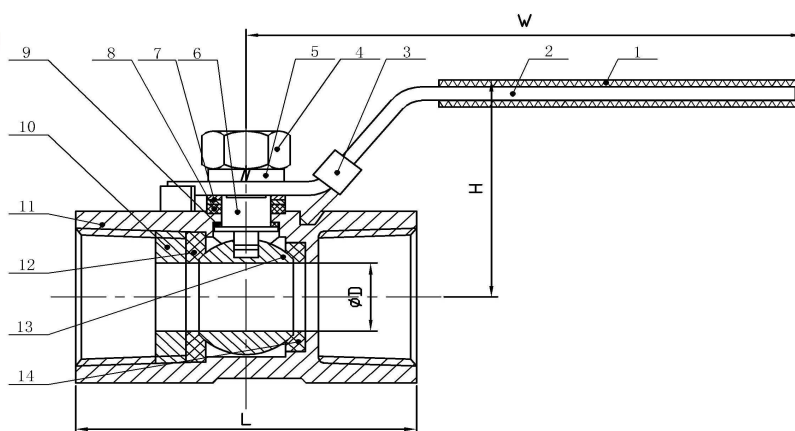

1 PC BALL VALVE (REDUCED PORT) (mm)

DN	G	D	L	H	W	Unit weight(KG)	
8	1/4"	5.0	39.5	29.0	63.0	0.060	
10	3/8"	7.0	43.5	32.0	90.0	0.090	
15	1/2"	9.0	55.0	39.0	93.0	0.152	
20	3/4"	12.5	58.5	43.0	93.0	0.230	
25	1"	15.0	69.5	50.0	110.0	0.384	
32	1 1/4"	20.0	76.5	55.0	110.0	0.630	
40	1 1/2"	25.0	81.0	70.0	140.0	0.770	
50	2"	32.0	95.0	68.0	140.0	1.190	

MATERIAL LIST

ITEM	DESIGNATION	MATERIAL
1	PLASTIC COVER	PLASTIC
2	HANDLE	304
3	LOCKING	304
4	STEM NUT	304
5	SPRING WASHER	304
6	STEM	304
7	PACK RING	304
8	STEM PACKING	PTFE
9	THRUST WASHER	PTFE
10	CAP	CF8/CF8M
11	BODY	CF8/CF8M
12	BALL SEAT(A)	PTFE
13	BALL	304/316
14	BALL SEAT(B)	PTFE

FEATURES:

- Handle with lock can be choiced.
- Working pressure:1000PSI(PN64).
- Working temperature:-10℃ to 150℃.
- Suitable medium:W.O.G.
- Thread: BSP,BSPT,DIN,NPT.
- PED97/23/EC(CE0038)Approved.
- Inspection Testing:API598,EN12266.
- Size of carton:28.5×25.5×18.5cm.